



V300

COMMERCIAL VINYL SERIES

Casement | Project-Out | Fixed









 **Product Material**
uPVC Vinyl

 **Frame Depth**
3 1/4"

 **Rating**
Casement: CW50
Project-Out: CW50
Fixed: CW50



Talo Apartments
Golden Valley, MN
Developers: 394 Associates LLC
Architect: Tushie Montgomery
Contractor: Greiner Construction
Dealer: Scherer Bros. Supply

 Design Pressure Casement: 50 Project-Out: 50 Fixed: 50	 U-Value* Casement: .17 - .41 Project-Out: .17 - .42 Fixed: .14 - .45
 Air Infiltration Casement: <.30 Project-Out: <.30 Fixed: <.30	 SHGC* Casement: .09 - .51 Project-Out: .09 - .51 Fixed: .11 - .68
 Water Resistance Casement: Up to 7.5 Project-Out: Up to 7.5 Fixed: Up to 7.5	 CR* Casement: 32 - 77 Project-Out: 32 - 77 Fixed: 33 - 77
 OITC^x Casement: 29 - 34 Project-Out/Fixed Combination: 29	 STC^x Casement: 34 - 41 Project-Out/Fixed Combination: 35
<small>*- U-Value, SHGC and CR ranges are NFRC certified based on I.G. combinations incorporating some or all the following: Low-E glass, clear glass, argon gas and/or air fill, and grids ^x-Ranges based on multiple I.G. combinations</small>	

FEATURES:

- ▶ Architectural grade uPVC vinyl frame
- ▶ Fusion welded sash and frame corners
- ▶ Integral Nail Fin
- ▶ 1" Insulating Glass
- ▶ Clean exterior appearance
- ▶ Multi-Point locking system with heavy commercial 4-bar arms on operating models
- ▶ Wide or Narrow sightlines on fixed models
- ▶ White and Sandstone uPVC vinyl (exterior/interior)
- ▶ Optional painted exterior (meets FGIA 615 finish)
- ▶ Textured laminate options for exterior and interior
- ▶ Use up to 8 floors with nail fin, up to 11 floors with receptor/subsill system
- ▶ Impact rated versions (V700 Series)



V300

COMMERCIAL VINYL SERIES

Casement (CW50)

Test size = 36" x 78"

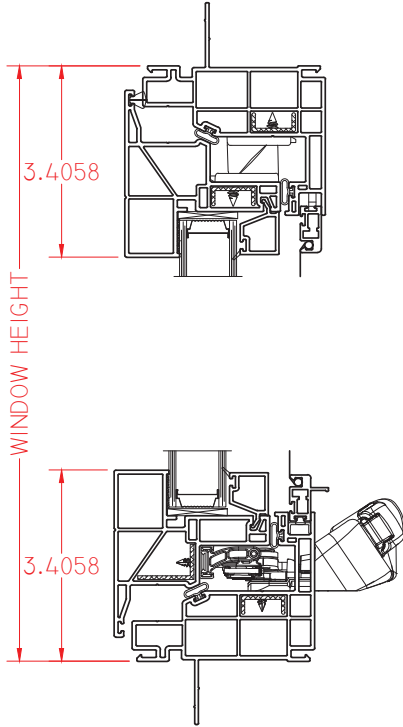

Project-out (CW80)

Test size = 60" x 32"

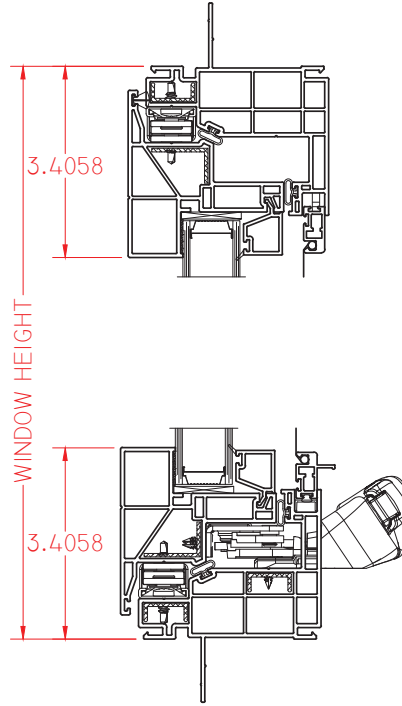

Fixed Narrow (CW50)

Test size = 78" x 78"

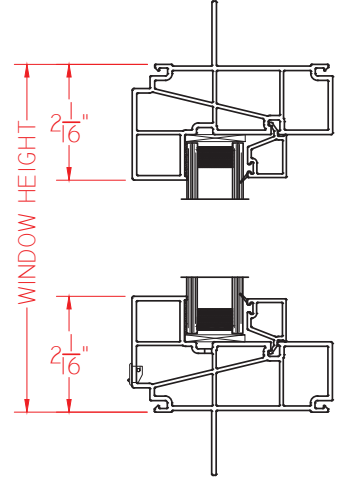

Fixed Wide (CW50)

Test size = 72" x 84"

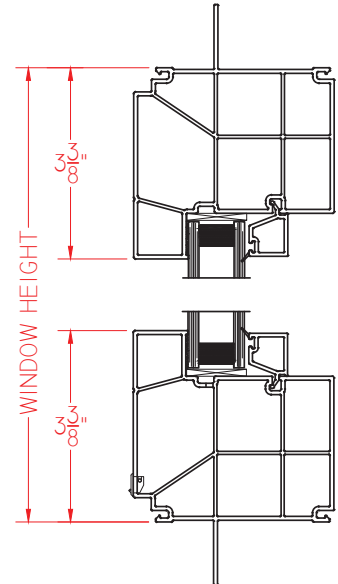

All ratings listed are NAFS certified.



The Yards
Kansas City, MO
Owner: Flaherty & Collens
Architect: KEM STUDIO
Contractor: M.W. Builders
Dealer: Ziegler Glass



QuakerCommercialWindows.com
1-800-347-0438
Commercial@quakerwindows.com